



---

# Instruction Manual

## ***Composite-ARF Extra 330L, 2.3 m***

---



# Instructions for Extra 330L IMAC-Airplane

Thank you very much for purchasing our Composite-ARF Extra 330L all composite aircraft, made with the revolutionary Total Area Vacuum Sandwich (TAVS) technology

Before you get started building and setting-up your aircraft, please make sure you have read this instruction manual several times, and understood it. If you have any questions, please don't hesitate to contact us. Below are the contact details:

**Email:** [feedback@composite-arf.com](mailto:feedback@composite-arf.com)  
**or** [techsupport@composite-arf.com](mailto:techsupport@composite-arf.com)

**Telephone:** Phone your C-ARF Rep!!! He will be there for you.

**Website:** <http://www.composite-arf.com>

This instruction manual aims to do 3 things:

- 1) Show you how to build your aircraft accurately and properly.
- 2) To explain about your fully-composite aircraft, and how to handle and maintain it.
- 3) How to set up and trim your finished IMAC type aircraft perfectly to give you the most enjoyment from it.

Below are a few of the TOC pilots who helped to design and modify our 3m Extra 330S to the championship-winning standard it is now at. And your 2.3m span Extra 330L is based on the design of that plane and the experience of these experts.



***Sebastiano Silvestri***

***Mike McConville***

***Ivan Kristensen***

***Jason Shulman***



Composite-ARF would like to thank all of these 4 very experienced pilots for their co-operation and help, which has made this 330 Extra aeroplane as good as it is today.

Of course all four of them are also Rep's for C-ARF, and if you want to ask them any questions you can email them (see our website for links) directly, or email your questions to us at 'feedback@composite-arf.com' and we will forward your comments to them. We are sure that they will answer you right away.

## **Liability Exclusion and Damages**

You have acquired a kit, which can be assembled into a fully working R/C model when fitted out with suitable accessories, as described in the instruction manual with the kit.

However, as manufacturers, we at Composite-ARF are not in a position to influence the way you build and operate your model, and we have no control over the methods you use to install, operate and maintain the radio control system components. For this reason we are obliged to deny all liability for loss, damage or costs which are incurred due to the incompetent or incorrect application and operation of our products, or which are connected with such operation in any way. Unless otherwise prescribed by binding law, the obligation of the Composite-ARF company to pay compensation is excluded, regardless of the legal argument employed.

This applies to personal injury, death, damage to buildings, loss of turnover and business, interruption of business or other direct and indirect consequent damages. In all circumstances our total liability is limited to the amount which you actually paid for this model.

**BY OPERATING THIS MODEL YOU ASSUME FULL RESPONSIBILITY FOR YOUR ACTIONS.**

It is important to understand that Composite-ARF Co., Ltd, is unable to monitor whether you follow the instructions contained in this instruction manual regarding the construction, operation and maintenance of the aircraft, nor whether you install and use the radio control system correctly. For this reason we at Composite-ARF are unable to guarantee or provide a contractual agreement with any individual or company that the model you have made will function correctly and safely. You, as operator of the model, must rely upon your own expertise and judgement in acquiring and operating this model.

## **Supplementary Safety Notes**

### **Pre-flight checking:**

Before every session check that all the model's working systems function correctly, and be sure to carry out a range check.

The first time you fly any new model aircraft we strongly recommend that you enlist the help of an experienced modeller to help you check the model and offer advice while you are flying. He should be capable of detecting potential weak points and errors.

Be certain to keep to the recommended CG position and control surface travels. If adjustments are required, carry them out before operating the model.

Be aware of any instructions and warnings of other manufacturers, whose product(s) you use to fly this particular aircraft, especially engines and radio equipment.

Please don't ignore our warnings, or those provided by other manufacturers. They refer to things and processes which, if ignored, could result in permanent damage or fatal injury.

## Attention !

This IMAC-Aircraft is a high-end product and can create an enormous risk for both pilot and spectators, if not handled with care, and used according to the instructions. Make sure that you operate your Extra according to the AMA rules, or those laws and regulations governing the model flying in the country of use.

The engine, servos and control surfaces have to be attached properly. Please use only the recommended engines, servos, propellers, and accessories supplied in the kit.

Make sure that the 'Centre of Gravity' is located in the recommended place. Use the nose heavy end of the CG range for your first flights, before you start moving the CG back to a more critical position for 3D-maneuvers. If you find that you need to relocate your batteries or even add weight in the aircraft to move the CG to the recommended position, please do so and don't try to save weight or hassle. A tail heavy plane, in a first flight, can be an enormous danger for you and all spectators. Fix any weights, and heavy items like batteries, very securely to the plane.

Make sure that the plane is secured properly when you start up the engine. Have at least 2 helpers hold your plane from the tail end or from behind the wing tips before you start the engine. Make sure that all spectators are behind, or far in front, of the aircraft when running up the engine.

Make sure that you range check your R/C system thoroughly before the first flight. It is absolutely necessary to range check your complete R/C installation first **WITHOUT** the engine running. Leave the transmitter antenna retracted, and check the distance you can walk before 'fail-safe' occurs. Then start up the engine, run it at about half throttle and repeat this range check with the engine running. Make sure that there is no range reduction before 'fail-safe' occurs. Only then make the 1st flight. If you feel that the range with engine running is less than with the engine off, please contact the radio supplier and the engine manufacturer and **DON'T FLY** at that time.

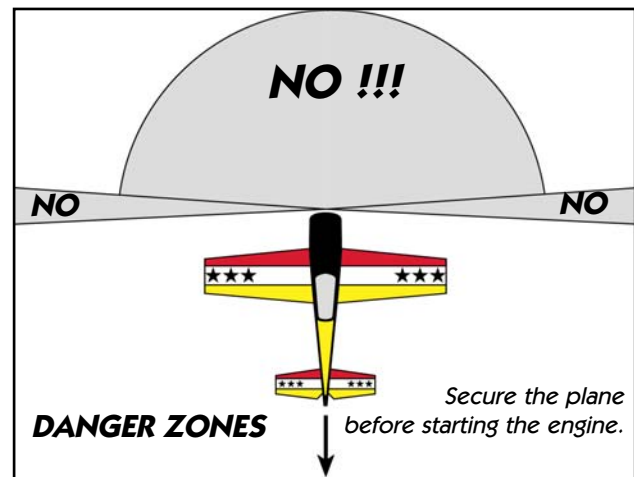

Check for vibrations through the whole throttle range. The engine should run smoothly with no unusual vibration. If you think that there are any excessive vibrations at any engine rpm's, **DON'T FLY** at this time and check your engine and your propeller for proper balancing. The lightweight sandwich composite parts don't like too much vibration and they can suffer heavy damage. The low mass of all the parts results in low physical inertia, so that any excess vibrations can affect the servos and linkages.

Make sure that your main spar tube is not damaged or bent. Check that the front and rear anti-rotation pins for the wings and horizontal stabiliser are located correctly in their holes, and are not loose. Check that the 4 plastic wing retaining nuts are tight, that the M3 bolts retaining the horizontal stabilisers on to the aluminium tube are installed and tight, and that the hinge wires for the rudder and elevators cannot come out.

If you carefully checked all the points above and followed our advice exactly, you will have a safe and successful first flight - and many hours of pleasure with your Composite-ARF Extra 330L.

# General information about fully-composite aircraft structure and design

All the parts are produced in negative molds, manufactured using vacuum-bagged sandwich construction technology. All parts are painted in the moulds, either single colour or designer colour schemes. A new production method, called TAVS, (Total Area Vacuum Sandwich) enables us to present this aircraft with incredible built-in strength, while still being lightweight, and for a price that nobody could even consider some years ago. This production process has huge advantages, but a few disadvantages as well. These facts need to be explained in advance for your better understanding.

## Description of Parts

### The Wings:

Both wing halves are made in negative moulds, and fully vacuum bagged. Only 2 layers of 2 oz. cloth in combination with a very hard 2 mm foam sandwich form a hard and durable outer skin. Because of this TAVS technology no additional structural parts are needed except for the aileron and main spar, which is a large 40mm diameter aluminium tube.

The ailerons are hinged already for you. They are laminated in the wing mould and are attached to the main wing with a special nylon hinge-cloth, sandwiched between the outer skin and the foam. This nylon hinge is 100% safe and durable. You will never have to worry about breaking it, or wearing it out. There is no gap at all on the top wing surface, and there is a very narrow slot in the bottom surface, where the aileron slides under the main wing skin during down throw. This hinge setup is the cleanest you can ever obtain, but you have to take some care during assembly for proper installation and servo set up.

First, the hinge line is on the top surface of the wing, not in the centre. This is NOT a disadvantage, if you set in about 10% NEGATIVE aileron differential in your transmitter program. This means that the 'down' throw needs to be about 10% more than the up throw.

Why? Because the axis of the hinge is not at the centreline of the aileron, so it moves slightly in and out when it travels, and the aileron gets a little "bigger" in surface area when moving up, and "smaller" when moving down. This is why you have to set the negative differential in your transmitter to compensate for the size changing. 10% is a good starting point, and you will find out the exact setting during the first flights, doing fast vertical rolls and watching the fuselage rolling in a perfect line. You can set it perfectly, this is guaranteed.

The bottom slot needs some explanation, too. The cut line is exactly in the correct position so that the aileron slides under the wing skin smoothly. If the cut was a few mm forward or back, it would not work properly. So, make sure that the lip is not damaged, and that the aileron slides under this lip perfectly. It will NOT lock at any time, as long as the lip is not damaged. If damage occurs to the lip, you can cut off 2-3 mm, but you should NEVER need to cut off more than this.

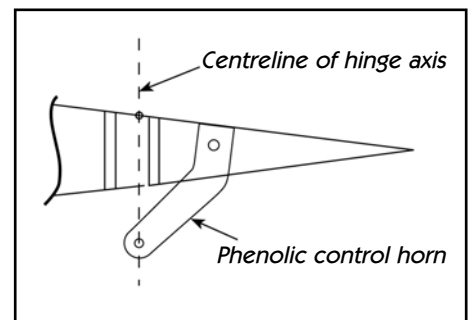

Make sure that the control horns are glued into the ailerons properly. The hole in the phenolic horn for the quick-link needs to be exactly perpendicular to the hinge axis line, and in this manual we show you a simple way to ensure that the horns in all pairs of control surfaces will be identical, making it easy to set up your R/C for accurate flying manoeuvres.

For normal pattern flying one good servo for each aileron is enough, but if you want to do more radical 3D manoeuvres, then fit 2 servos per aileron. We have supplied the extra 2 servo mounts for you in the kit - all you need to do is cut out the servo cover hatches that are marked on the bottom surface of the wing, and construct in the same way as the standard inner servo mounts. The result is a rock solid servo mount and linkage, but still easy to maintain or exchange.

The wings are attached to the fuselage using the 4 threaded aluminium dowel anti-rotation pins, with 4 plastic nuts inside the fuselage. If the aluminium dowels come loose in the wing, the wing will slide outwards, away from the fuselage, and the main spar will definitely break. So take great care to inspect the glue joints of these anti-rotation dowels in the wing **REGULARLY**. Excessive vibrations or hard shocks can cause the glue joints to weaken or break. Monitor these joints whenever you set up your plane. Never forget to tighten the nuts inside the fuselage. Your flight will end after 100 ft and you will have to fix a hole in your club's runway. Please **DO NOT** modify these attachment dowels in any way, their perfect function is proven for many years.

### **The Fuselage:**

The fuselage is also made in negative moulds, and (except for the bottom surface) it is also all constructed using TAVS technology. All the loadbearing internal parts are glued in during manufacture, to ensure accurate location and reduce the assembly time for you. The sleeves for wing and stab spar tubes, and the holes and reinforcement plates for the anti-rotation dowels, are already installed. There is no need to even check the incidences - you can be assured that these are already set in the moulds so that no adjustment is necessary.

The landing gear mount is strong and doesn't need any extra reinforcement. You have an extremely light weight fuselage, and the gear loads need to be led into the structure gently. No glue joint needs to be stronger than the materials that it is attached to, as it would just result in increased weight for no advantage. The landing gear is a fairly flexible design, which works very much like shock absorbers. This plane is not made for crashing, but the landing gear will take some hard landings without problems. Do not change or modify it, as the results would only be negative. We had plenty of time and experience to engineer the strength needed in this area - and we did !

The firewall is preinstalled, and provides plenty of strength for up to any 75 cc engines on the market today. The mounting holes in the firewall are pre-drilled during manufacture, and the corresponding holes that you need to drill in the moulded motor dome are marked for you in the mould for the greatest accuracy. See the Engine Installation section for adjusting the mount and setting thrust angles.

The engine cowling and canopy frame should be attached using the method shown here. This is only a little work and all suggested mounts are tested and proven for many years.

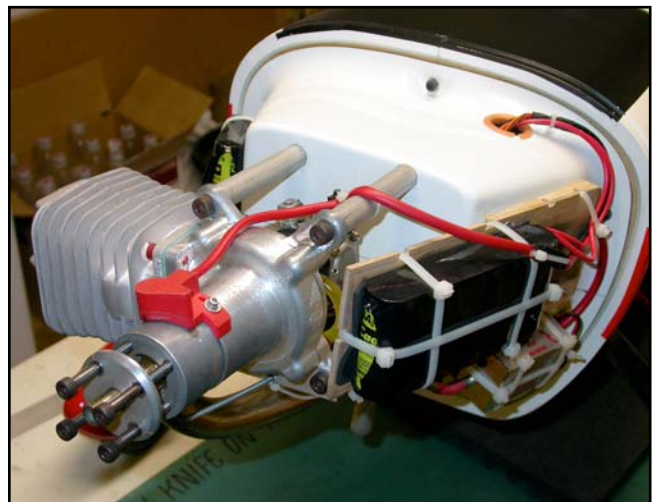

**The Stabilisers:**

The stab parts are also vacuum bagged sandwiched. The rudder and elevator control surfaces are hinged with 2mm steel rods, fitted through phenolic hinge bearing plates installed during manufacture to ensure perfect alignment.

The rudder and elevator design allows for at least 50 degrees throw. For the Extra it is mandatory that the tail area is extraordinarily light weight, so the stab is designed for one powerful servo installed in each half. All the structural parts are preinstalled. The horizontal stabs are mounted with one 20mm tube and one aluminium anti-rotation pin each. Please remember during assembly of the plane that every gram of weight should be saved in the tail area.

**Take Care:**

Composite sandwich parts are extremely strong, but fragile at the same time. Always keep in mind that these contest airplanes are designed for minimum weight and maximum strength in flight. Please take care of it, especially when it is being transported, to make sure that none of the critical parts and linkages are damaged. Always handle your airplane with great care, especially on the ground and during transport, so you will have many hours of pleasure with it.



*The 2.3m prototype stabilisers.*

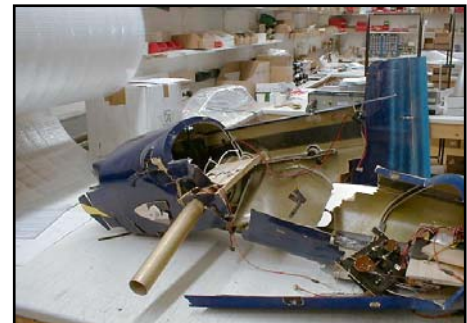

*We don't want your plane to look like this ... !*



*A couple of views inside the new factory, showing a small part of the finishing area, and the vacuum/oven tables for the composite mouldings.*



## The 'Paint Job'

Occasionally customers notice certain problem areas with composite parts.

But the question is: Are these real problems, or are they just a misunderstood sign of high-tech construction, proving the high-end composite technology?

### Seams:

ALL composite parts have seams. They are there today, and they will be there forever. You will have to get used to them ... or you'll have to touch up the paint yourself !

But what is a seam? A seam on the fuselage, especially already painted in the mould, proves that this is a vacuum-bagged high-tech part, made in negative moulds. Our seams are fine and straight, no negative impression at all ... but they are there. When possible we include 5mm wide strips of self-adhesive vinyl, painted in exactly the same colour as the plane for you to cover the seams if you want.



*(above) One of our 2.6m Extra's, in the 'Fantasy red/yellow' paint scheme ... all painted in the moulds !*

### Paint flaws:

If the aircraft is painted in the moulds, you can save a lot of weight. At least 2 lbs ... and that is definitely worth saving !

*(below) One of our customers with the 3m Extra 330S practising his tail-in hovering !*

A negative paint job is very complicated to make. The painter never sees the result of his job. He cannot see the design growing and developing - he is painting 'blind'. He even cannot see little mistakes and flaws, and even if he COULD, he could not correct them. The maximum time to apply a designer paint scheme in the mould is no more than 20 minutes. It is a big rush against time, because even if it is just few minutes too slow then the masking cannot be removed without pulling off the paint itself ! This is a BIG challenge, but the result is extraordinarily impressive. Even with slight flaws the general appearance of these one-of-a-kind paint jobs is unique.



In a 'positive' paint job some effects can never be done. Just think about the shadows, peel backs, highlights, and 3D effects - and all with a perfectly flat and uniform surface for optimum airflow and aerodynamics.

Truly hard to do, but still possible, are the paint jobs which seem to be so simple at first glance: Schemes with straight lines and stripes. Quite easy with positive painting, but it's very hard masking the lines in the negative moulds, because we cannot assemble the parts before masking. To get the stripes lining up exactly at the rudder, wing and cowling joints is therefore almost impossible. This is why we suggest using thin vinyl trim to make sure that these stripes line up perfectly. Sometimes it is necessary to do that, and it is definitely not a quality problem or a "flaw". It comes back to what is possible, and what is impossible.



*Extra 330L (2.6m span) in Shulman 2000 scheme, painted in the moulds.*

If you want to have a really perfect paint job, then you might decide to have a single colour version and have it painted by yourself or your friend.

But don't forget: Consider the additional cost, consider the additional weight, consider that even if it is painted 'positive' there will be areas you won't be happy with.

Of course you won't complain, because you created these flaws yourself... !



*This is the FiberClassics (now 'Composite-ARF') force at the TOC 2000, with all models painted in the moulds.*

## Tools and Adhesives

### Tools etc:

This is a very quick and easy plane to build, not requiring difficult techniques or special equipment, but even the building of Composite-ARF aircraft requires some suitable tools! You will probably have all these tools in your workshop anyway, but if not, they are available in all good hobby shops, or hardware stores like "Home Depot" or similar.

1. Sharp knife (X-Acto or similar)
2. Allen key set (**metric**) 2.5mm, 3mm, 4mm & 5mm.
3. Sharp scissors
4. Pliers (various types)
5. Wrenches (**metric**)
6. Slotted and Phillips screwdrivers (various sizes)
7. M3 tapping tool (**metric**)
8. Drills of various sizes
9. Small spirit level
10. Dremel tool (or Proxxon, or similar) with cutting discs, sanding tools and mills.
11. Sandpaper (various grits), or Permagrit sanding tools (high quality).
12. Carpet, bubble wrap or soft cloth to cover your work bench (most important !)
13. Car wax polish (clear)
14. Paper masking tape
15. Denaturated alcohol, or similar (for cleaning joints before gluing)

### Adhesives:

Not all types of glues are suited to working with composite parts. Here is a selection of what we normally use, and what we can truly recommend. Please don't use inferior quality glues - you will end up with an inferior quality plane, that is not so strong or safe.

1. CA-Glue 'Thin' and 'Thick' types. We recommend ZAP, as this is a very high quality.
2. ZAP-O or PlastiZAP, odourless (for gluing on the clear canopy)
3. 5 minute-epoxy (highest quality seems to be Z-Poxy)
4. 30 minute epoxy (stressed joints must be glued with 30 min and NOT 5 min epoxy).
5. Epoxy laminating resin (12 - 24 hr cure) with hardener.
6. Milled glass fibre, for adding to slow epoxy for strong joints.
7. Microballoons, for adding to slow epoxy for lightweight filling.

At Composite-ARF we try our best to offer you a high quality kit, with outstanding value-for-money, and as complete as possible. However, if you feel that some additional or different hardware should be included, please feel free to let us know. Email us: [feedback@composite-arf.com](mailto:feedback@composite-arf.com). We know that even good things can be made better !

## Accessories

Here is a list of the things you may need to get your Composite-ARF Extra 330L in the air. Some of them are mandatory, some of them can be chosen by you. What we list here are strongly recommended parts, and have been thoroughly tested.

1. Power servos (min. 6 required). We recommend JR 8411 at least for the elevators and ailerons. You can either use a pair of JR 8411's, or JR 4421's for rudder control.
2. Throttle servo (1) Any standard servo will do (eg: JR/Graupner 4041)
3. Aluminium Spinner 100 mm dia (4").
4. Main wheels 105 - 125 mm (4.25 - 5"). Kavan Light or Dubro wheels are recommended.
5. Engine DA-50. This is the recommended engine for your Extra 330L. The instructions refer to that engine several times. But you can use any other 50 to 75cc engine as well.
6. Mini-Pipe Muffler Set. (Consists of 1 canister, 1 aluminium header, Teflon coupler, spring clamp, and mounting hardware.
7. Standard exhaust muffler. (optional, if noise is not a problem at your field)
8. High quality heavy-duty servo extension cables, with gold connectors. High quality receiver switch (gold contacts). 'Y' leads, etc. Ceramic/ferrite chokes.
9. Receiver battery. Either one 2000 mAH pack, or 2 x 1200/1400 mAH packs if preferred.
10. Fuel tank (750 - 950 ml) with gasoline stopper. We use Dubro.
11. Cable ties in various lengths.
12. Propeller Composite-ARF/G-Force 22x10. This prop was developed especially for 50 - 62cc engines used on our Extra 330L. High power, low noise and 100% precisely balanced due to CNC technology. Custom painted available. Perfect thrust and speed range for pattern and 3D-aerobatics.

***Did you read the hints and warnings above and the following instructions carefully?***

***Did you understand everything in this manual completely?***

***Then, and only then, let's start assembling your Composite-ARF Extra 330L. If not, please read again before you start the assembly.***

## Building Instructions

### General Tips:

We recommend that you follow the order of construction shown for the fuselage, as it makes access to everything easier and saves time in the end. The wings and stabs can be done at almost any point, and only need servos and horns installing anyway.

The first thing to do is protect the finished paint on the outside of the model from scratches and dents during building - so cover your work table with a piece of soft carpet, cloth or bubble-plastic. The best way to stop small spots of glue etc., getting stuck to the outside of the fuselage is to give the whole model 2 good coats of clear car wax first, *but* you must be sure to remove this 100% properly before painting trim lines, if any. If you prefer you can cover the majority of the fuselage with the bubble-plastic used to pack your model for shipping, fixed with paper masking tape, which also protects it very well.

When sanding any areas of the inside of the fuselage to prepare the surface for gluing something on to it, do NOT sand right through the layer of glasscloth on the inside foam sandwich ! It is only necessary to rough up the surface, with 60/80 grit or equivalent, and wipe off any dust with alcohol (or similar) before gluing to make a perfect joint.

Before starting construction it is a good idea to check inside the fuselage for any loose glass fibres that could cut your hands, and a quick scuff over any of these with a coarse Scotchbrite pad will remove them.

**Note:** It is very important to prepare the inside of the fuselage properly, by roughing up and cleaning the surface, before gluing *any* parts to it.

## Landing Gear

The 1st job is to fit the landing gear legs (wheel pants can be done later) - and you can leave these in place, as they will protect the bottom of the fuselage during assembly.

Composite-ARF developed a new carbon fibre landing gear for the Extra. It consists of 45 deg laminated carbon fibre cloth and a huge number of carbon tows inside, all made under vacuum and heat-cured. However it is still light weight, and retains enough flexibility to take the shock out of any landings that are less-than-perfect!

Mark the centreline on each landing gear, and drill 2 holes with a sharp 6.5mm Ø drill as shown in the photo. The centres of the holes are measured from the bend in the leg that will be flush with the outside of the fuselage. The outer hole is 38mm from the bend, and the inner hole is 52mm from the 1st hole.

Fix the legs into the plane with the M6 x 20 bolts and 13mm Ø washers into the blind nuts installed during manufacture. Both main legs are identical, and can be used either side.

## Finished in 2 hours

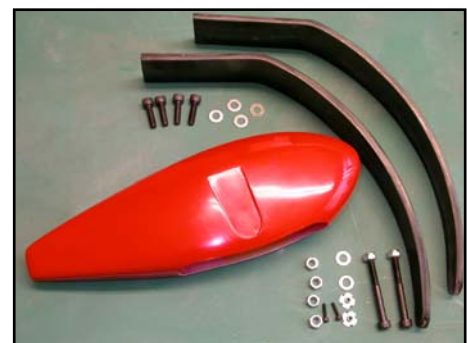

(above) The parts used to assemble the main Landing Gear.

(below) drill 2 x 6.5mm Ø holes for bolting in the Landing Gear.



The wheel axles are M6 x 55 hardened steel bolts, fitted through 6mm holes drilled in the bottom of the landing legs. There is a small dimple moulded into the legs for the exact location of the holes.

The head of the bolt goes on the *outside* of the wheel, inside the wheel pant. The order of the items on the bolt is: Bolthead, washer, wheel hub, 6mm wheel collar, M6 nut, washer, carbon landing gear leg, and finally another washer and the locking nut. You may need to adjust the thickness of the wheel collar, or add a couple of extra washers to get the wheel exactly centred in the wheel pant. A drop of loctite on the inner M6 nut is good insurance.

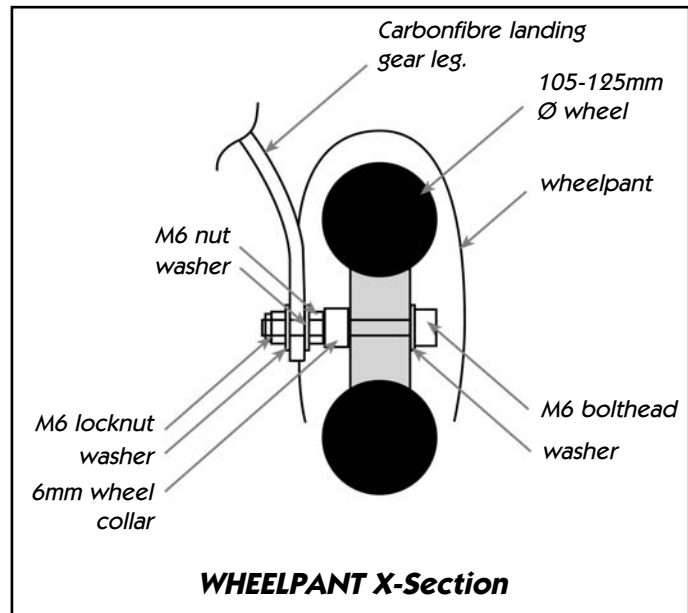

It is just possible to assemble everything on the wheel and squeeze the wheel pant open enough to insert it all together, depending on the wheel diameter and thickness. If using a Dubro 104mm (4.25") wheel this works fine. If using a larger Ø wheel it is easiest to drill an 8.5 mm clearance hole in the outside of the wheelpant to insert the bolt through, and this is a much easier method anyway.



Because the wheel pants have a shaped moulded-in recess for the landing gear leg it is not necessary to fix them to the leg with a separate bolt, but if you want to make sure the alignment does not change you can drill a 2.5mm hole through the main leg into the plywood reinforcing plate inside the wheelpant, tap M3 thread in the hole, and use a short M3 bolt for permanent alignment.



*Optional tailwheel assembly from Composite-ARF.*

You can use any 4.25" - 5" main wheels. Kavan wheels are very lightweight, but not very durable on asphalt runways, and Dubro wheels are a little heavier but much more solid.

Any standard tailwheel assembly from a good hobby store is suitable for your Extra. The tail wheel setup shown in these photos is an optional part available from C-ARF, and is mounted with 4 sheet metal screws and 2 plastic 'U' brackets under the fuselage, screwed into the plywood reinforcement installed in the fuselage at the factory.

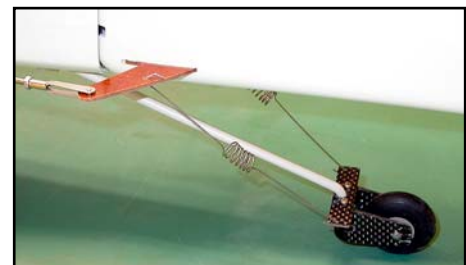

You do not need to make the tailwheel steerable, a simple castoring action is fine. However, for asphalt runways you may prefer to connect it to the rudder horn with 2 springs as shown in the photo. It's easy to make these by winding some 0.8mm or 1.0mm Ø piano wire around a 5mm drill bit, with a small hook in each end to connect to the tailwheel steering arms and the rudder horn. See photos.

Remember - keep it lightweight at the tail end!

## Cowling

**Finished in 1 hour**

Attaching the cowling is easy, as it is already cut and trimmed at the factory, and should need almost no adjustment for a perfect fit. With the main undercarriage legs bolted into place, put the main spar tube through the sleeve in the fuselage and use a small spirit level on top of the tube to make sure the plane is exactly level (side to side). Shim under the undercarriage legs as necessary to get it level on your building table.



If necessary, sand the inside back edge of the cowl to get a good flush fit between the cowling and the fuselage. Trial fit the cowling, and again use the spirit level, or an incidence meter as shown, on the flat part of the cutout in the front of it to make sure that it is level and properly centred on the fuselage. Mark a centreline on the top of the cowl and the fuselage, on small pieces of masking tape, and then tape the cowling firmly in position.

Drill 7 small holes (1.7 mm Ø), about 125 mm apart, with the first hole at the top centreline of the cowl, exactly in the centre of the overlapping area, which is approx. 5mm from back edge of cowl. Make sure that the 2 bottom holes are about 15 mm from the edge of the square cutout under the cowling. Secure the cowling in place with 7 small sheet metal screws and small washers into the main engine firewall. If using a DA-50 motor you will find that you need almost no cut-outs in the cowling at all, just a small one for the spark-plug cap as seen on the photo on page 29.

## Canopy Frame

**Finished in 3 hours**

The canopy frame fits the fuselage already. It is important to finish the mounts step by step as advised below.

Mill 6 slots (3mm wide x 20mm long) into the canopy frame in the positions shown, with the outside edge of the slots approx. 4 mm inside the outer edge of the canopy frame. Then tape the canopy frame to the fuselage in the correct position, and mark through these slots onto the fuselage. Take off the canopy frame and mill the slots in the fuselage.

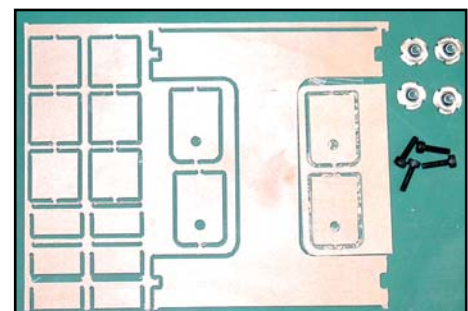

Now glue all 6 of the 20mm square milled plywood pieces to the inside of the fuselage directly below 6 slots, making sure that the inner face is exactly vertical. Because of the shape of the fuselage you will need to thicken the epoxy (30 minute type with some milled fibre and microballoons), especially for the front mounts. Make sure that these are properly glued in place and that the space between the plywood plates and fuselage is completely filled with epoxy.

*Milled plywood parts for the canopy frame fixing. The 'H' shaped part is used for reinforcing under the fuel tank base later.*

Drill a 3mm hole through the fuselage in the centre of the front and rear mounting plates only

(not the middle 2 plates). Take the 4 plywood rectangles with the milled holes, and glue the four M3 blind nuts in place with 30 minute epoxy. Bolt the 4 plates inside the plywood plates that are glued inside the fuselage with M3 x 12 bolts, so that the tops of the plates stick up through the milled slots by about 5mm. Cut off excess length if necessary.

Put some clear tape around the slots on the fuselage and frame and wax these areas carefully. Sand the areas around the slots inside the canopy frame with rough sandpaper. Fix the canopy frame in place with tape and then glue the 4 plywood parts to the canopy frame with 30 minute epoxy and some milled glassfibre. If the joint area was waxed carefully, you can take off the canopy frame in about 1 hour and you are almost finished.

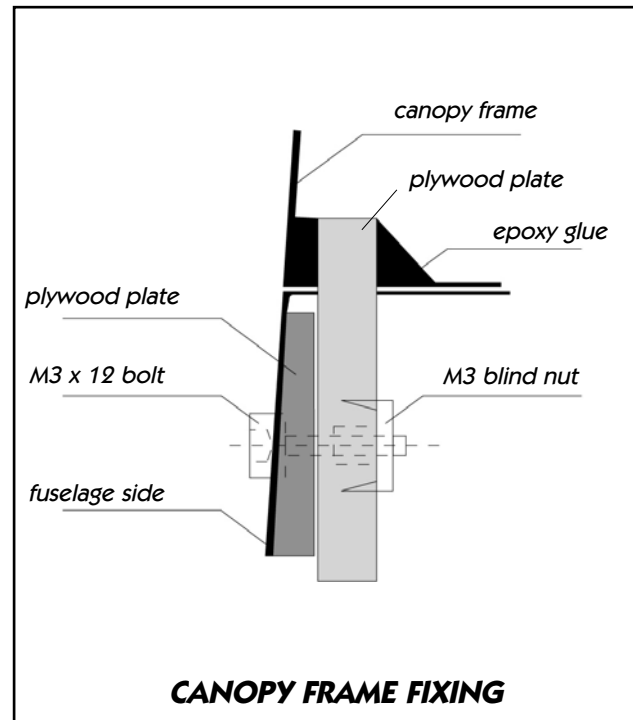

Slide in the 2 centre guides (small plywood parts, no hole) and glue them in with 30 min epoxy also. These centre guides make sure the middle of the canopy frame stays aligned properly with the fuselage.

Fitting the clear canopy into the frame is a little bit tricky, but this is a step by step guide of how to do it successfully:

Sand the inside edges of the canopy frame carefully with rough sandpaper, to ensure a perfect fit of the canopy inside. Cut the outer border of the clear canopy with sharp scissors. We recommend that the canopy is slightly warmed up with a hair dryer to prevent cracking - but be careful not to melt or deform it ! When the canopy fits inside the frame roughly, use a felt pen to mark the final cut on the clear plastic. Then cut it to the exact shape with a 6 mm overlap all around.

First make several hand holds with paper masking tape (see photo) to make holding and positioning the canopy easy. Push the canopy up tightly inside the back of the frame and fix the bottom 2 back corners with one drop of slow CA each (ZAP-O or Plasti-ZAP recommended).

**Note:** Do NOT use any CA accelerator/kicker - you will immediately 'fog' the clear canopy!

Tape the rest of the canopy roughly in place, and mount the canopy frame to the fuselage (use all 4 bolts), and tape the back of the canopy frame to the fuselage. Using the masking tape handles to pull the canopy outwards firmly against the frame, working from the back towards the front, glue the edges of the canopy in place in 2 more places each side, with just a single drop of CA at each position, all the time checking that the edge of the canopy is tight up against the frame at the front.



Then make visual check from the front and back to make sure sure that the canopy is straight. Now that the canopy is fixed in position and cannot twist or warp anymore, you can carefully remove the frame from the fuselage, and glue the rest of the canopy firmly in place from the inside. If you prefer you can use 30 minute epoxy or similar for gluing all the edges to the frame at this stage.

If you wish you can tint the inside of the canopy using one of the aerosol spray paints used for painting the inside of polycarbonate car bodies (eg: the Tamiya or Lexanit ranges). Use many very light coats to get even coverage.

The 4 holes for the heads of the M3 bolts that hold the canopy in place need to be 'counterbored' into the outside surface of the fuselage, so that the bolt heads do not squash the relatively soft foam cored vacuum moulding. Counterboring means making a larger hole for the bolt-head to go in, so it sits flush with the outside surface of the fuselage, and the head sits against a *flat* surface inside the hole - not an angled surface like that made with a normal countersink. The easiest way to do this is with a Dremel and a small mill. Make the counterbored bored holes 6mm Ø and about 5mm deep, so that the bolt head sits against the plywood squares inside the fuselage. Even better is if you glue small metal washers into the holes for the bolts to sit flat against.

**Note:** This 'counterboring' technique also needs to be used in the bottom surface of both horizontal stabs for the M3 bolts that hold them onto the 20mm aluminium tube.

## Horizontal Stabs

The stabs are 99% finished at the factory, and only need the servos, elevator horns and linkages installing.

Insert the 20mm aluminium tube supplied in the fuselage sleeve, and install both stabs to check the fit between the root ribs and the fuselage. You might have to sand the root of the stabs slightly to make a perfect joint with no gap. If the tube is too long you will have to shorten it a little.

Attach the elevators to each stab using the 2mm steel hinge wires provided. Make a 90° bend in one end of them, about 10mm long, and a small point on the other end to make it easier to insert them through the holes in the



*(below) Use masking-tape handles to pull the clear canopy tightly against the canopy frame while gluing it in position.*



*(above) Counterbore the 4 holes for the canopy fixing bolts so that the bolt heads sit against the plywood plates inside the fuselage.*

## Finished in 3 hours

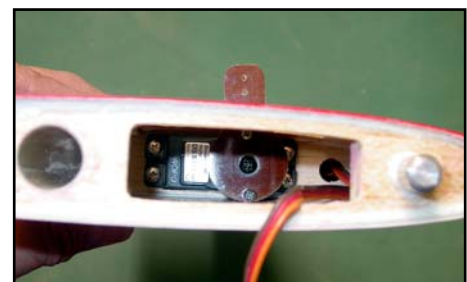

*Elevator servo installed, with C-ARF servo horn. Drill an 8mm Ø hole in the rib about 15mm in front of servo for cable and connector.*

phenolic hinge plates. Be careful inserting the hinge wires, and if they are a bit stiff, then use a little grease on the wire. Don't use too much force, otherwise some of the phenolic plates inside might break loose. Leave the hinge wires a bit too long during construction, and only cut them off to exact length when the model is finished.

Fit the servos into the stabs. The mounting plates are installed for a standard sized servo, just slide the servo in from the root and secure with the usual screws. You will need to drill an 8mm hole in the rib about 15mm in front of the servo for the servo cable and connector. Because of the thin stab profile you have to install servo arms through the slots in the btm. of the stab, and you might need to make the slots 1mm wider if using C-ARF servo arms.

Next the elevator horns. The milled slots in the elevators should be 15 mm long and 15 mm deep, and may need to be lengthened towards the Trailing Edge a little bit. Adjust as necessary. Put a layer of masking tape over the milled slot, wax it carefully, and then cut out the hole to access the slot with a sharp knife. Place a strip of masking tape on the btm. surface of the elevator, and mark on it the exact position of the hinge axis.

Make the horn alignment template from thin scrap plywood (see photo) and mark the position for the quick-link hole in the horn exactly perpendicular to the hinge axis line on the tape. The hole should be 22 mm from the surface of the elevator. Drill a 1.5 mm Ø hole in the alignment template, and glue in a short piece of 1.5 mm wire with a drop of thin CA.

The standard C-ARF phenolic elevator horns need a small modification for the 2.3m Extra elevators only. Cut, or sand, a small angled piece off the bottom of each elevator horn as seen in the photo, and re-drill a 3 mm diameter hole where shown. This hole is to give a better mechanical fixing when gluing the horn in place. Trial fit the horn in the slot, and make sure that the wire in the alignment template fits in the hole that is milled in the horn. Mark the part of the horn that will be glued inside the elevator, and then remove it and scuff up both sides with coarse (60 grit) sandpaper or a Permagrafit tool. Protect the alignment template with clear plastic tape so that it does not get glued to the horn or elevator!

Glue the horn in place with slow epoxy (minimum 1hr cure) mixed with a little milled fibreglass, or a filled thixotropic epoxy like Loctite/Hysol 9462 or BVM Aeropoxy. Check that horn is at 90° to the surface of the elevator, and wipe excess glue off before cure. Repeat for the other elevator horn, and use this same method described above for the aileron horns, making sure that all of them are exactly the same distance from the hinge axis to ensure that control surface movements are the same.

**Servo choice:** The elevators can travel more than 50 degrees, and it is up to you whether you want to use this throw or not. The throw defines the kind of servo. If you are going to use the maximum throw for 3D manoeuvres, we definitely recommend digital servos like JR8411, or the

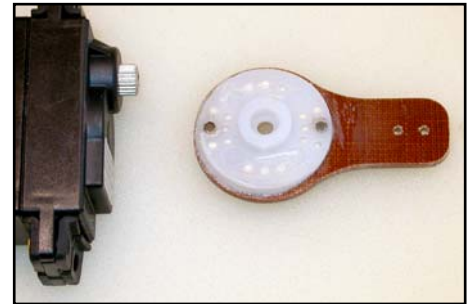

*(above) Shows C-ARF servo arm glued and screwed onto standard 25mm diameter servo output arm.*

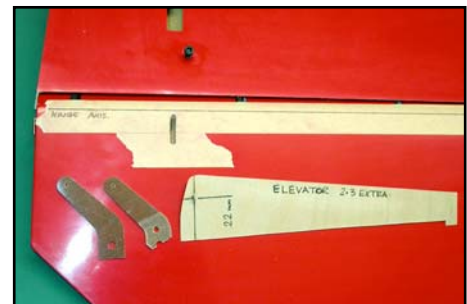

*(above) Shows horn alignment template made from scrap ply, and both standard and modified C-ARF control surface horns.*

new JR8511 or 8611. It is not just that the torque of a standard servo is not enough - it is the play in the gears which could cause problems centring, and high speed flutter might be the result. If you decide that 30-35° throw is sufficient for you, then you can go ahead with high torque standard servos as the precision and power will be fine the shorter standard servo arms.

When using the more powerful digital servos and larger throws we highly recommend that you use our Composite-ARF phenolic servo arms, designed for this kind of aircraft and included in the kit (see photo). These must be fixed to the standard (25 mm Ø) output arms supplied with the servo, and they are predrilled for the 2 small self-tapping screws so that line up exactly with the holes in the standard JR servo arm, automatically aligning them with the centre.

Rough up the bottom surface of the C-ARF servo arm and the top surface of the standard servo arm, apply a few drops of slow CA, or epoxy and milled fibre, and screw them together. Note that the C-ARF servo horns only just fit inside the 2.3m stabs, and you may find that you need to sand about 1mm off the bottom of the circular part so that it does not touch the inside of the top stab surface. This is important - do not forget it, other wise your servos will constantly buzz and draw extra current from your batteries.

Centre the servo arms using your R/C and make the linkages from the M3 threaded rods supplied, with 2 quicklinks and 2 x M3 locknuts for each stab. Don't forget to 'Loctite' the quick-link and lock-nut on one end of each linkage. Do NOT use ball-links if you use these C-ARF servo arms, because they will twist the servo arm and cause flutter. This is a solid experience and you should consider it a FACT.

The last job is to fit the M3 stab retaining bolts. Look inside the stabs and you will see the small plywood reinforcement plates between the spar sleeve and the bottom surface of the stab. Mark the bottom of both stabs in the centre of this plywood. Install the aluminium tube into 1 stab, and drill a 2.4mm hole right through the stab surface, the plywood plate, sleeve and into the 20mm aluminium tube. Thread the hole with an M3 tap and secure it with an M3 x 16 bolt. Fit both stabs to the fuselage, check that both stabs fit tightly to the fuselage shape at the roots, and then drill the hole in the other stab, thread as before, and secure with another bolt. Counterbore the holes for the boltheads (see canopy frame section).

Finally mill 2 slots into the fuselage between the front anti-rotation pin and the aluminium tube for the servo cables.

**Note:** Try to always leave the stab tube fixed in one stab, and never remove that one bolt, as it is very difficult to find the right position for the stab tube again if it is removed from both stabs!

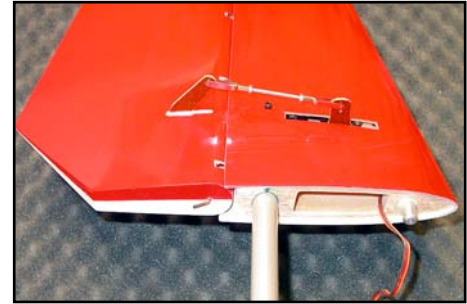

*Shows stab retaining bolt, 20mm aluminium spar, anti-rotation pin, C-ARF servo arm and linkage. Note the elevator horn is located slightly differently on production kits.*

## Rudder

The rudder is very easy. Trail fit the the double-sided phenolic control horn in the slot that is already milled in the base of the rudder, and mark the part that will be glued in. Remove it, mask the exposed parts and scuff the centre part on both sides with coarse sandpaper. Glue in place with slow epoxy and milled fibre, making sure that it is perfectly centred in the rudder. Fit the rudder to the vertical stabiliser with a 2mm steel hinge wire, in exactly the same way as the elevators. Check for smooth and free movement.

The 2 rudder servos are fitted to a mounting plate in the fuselage, that is not installed yet - but we included the instructions for it here so you can find them later!

Screw the servos into the tray, and screw firmly to the mount and the plywood reinforcing plates that are glued underneath it. Fit the supplied C-ARF rudder servo horns to a pair of standard 25mm servo output arms, in the same way as for the elevators, with both 'hooks' facing forwards and outboard. Make sure that they are centred accurately.

Join the 2 servo arms with 2 lengths of M3 threaded rod with the ball-links at each end, bolted through the milled holes in the arms with M3 x 16 bolts and nuts underneath. Don't forget to Loctite the nuts onto the bolts! Connect the servos together with a heavy duty 'Y-lead' and centre them with your R/C. Fit the C-ARF servo output horns to the servos and adjust the linkages very carefully so that there is no buzzing or humming from the servos at idle, or at full throw.

Make the pull-pull wires for the rudder from the hardware supplied, with a loop at the front that goes over the hooks on the output arms, and a quick-link with turnbuckle and locknut at the rudder end. For security pass the closed loop cable through the supplied 'crimping tubes' 2 times before squashing flat with pliers (see photo). Make sure that the wires are tight, and check and adjust regularly for the first few flights as the cables straighten out. Even a small amount of slop will prevent your Extra from perfect tracking.

**Servo choice:** The rudder is a huge surface on the Extra 330L and, just like the elevators, the choice of servo is up to you. A pair of JR4421 will be quite sufficient for pattern flying and normal manoeuvres, but if you plan to fly more radical 3D Freestyle, please fit high quality digital servos such as the JR8411 for the maximum precision and power. You will be pleased you did!

## Finished in 1 hour

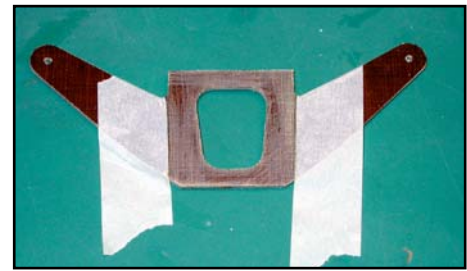

(above) Rudder horn roughed up with coarse sandpaper.

(below) Pass rudder cable thru' crimping tubes 2 times for safety.

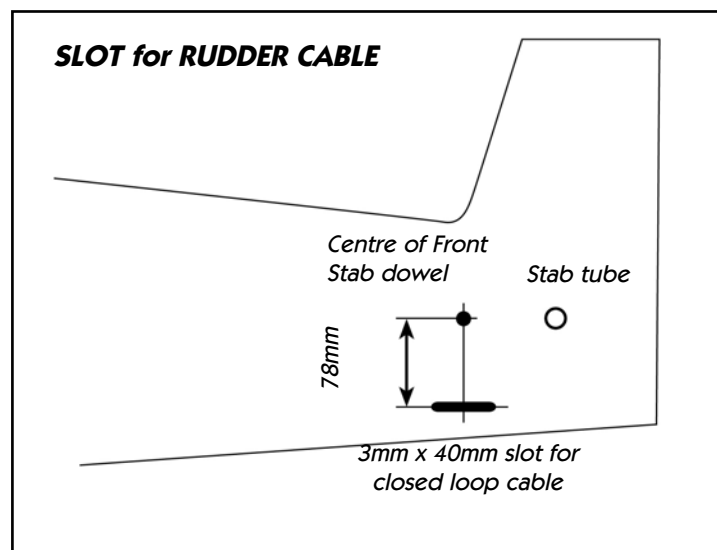
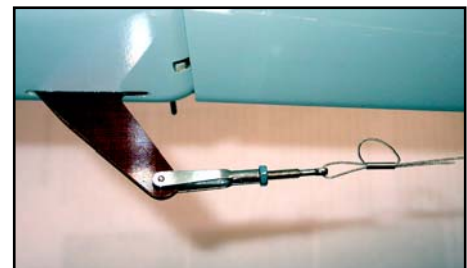

## Wings

Like the stabs, the wings are almost completely finished at the factory, and have already been installed on your fuselage to check the alignment. Slide the wings on and check for the perfect fit. You can sand the edges of the wing at the roots a little if needed. Fit the 4 plastic wing retaining nuts. We have already installed plywood plates inside the fuselage for the back nuts, but you will need to make 2 small rings of scrap 3mm plywood and glue them in for the front nuts - make sure they are vertical and perpendicular the the wing dowels to give a flat surface for the nuts (see photo on page 21).

Tighten the nuts and check how the root of the wing fits against the fuselage. For a perfect fit you may need to sand it slightly or use a smear of clear silicone sealant, but this is normally not necessary.

Assemble the servo mounts from the CNC milled plywood parts supplied, using thick CA. Fix the servos into the mounts with servo screws. Assemble 2 C-ARF servo arms onto the standard servo output arms, as described in the Horizontal stabiliser section, and fit them to the servos.

Sand the inside surface of the servo hatch plates with rough sandpaper. A good gluing surface is very important here! Trial fit the servos in their mounts to the plates, and when satisfied that the servo output arms are aligned in the centre of the slots in the hatch plates, and line up with the milled slots in the ailerons for the horns, glue in place with a few drops of thick CA. You may need to make the slots in the hatch about 1mm wider when using the C-ARF servo output arms. Finally remove the servos, and reinforce the glue joints between the servo mount and the servo hatch plate with slow (min. 30 minute) epoxy and milled fibre, with a nice glue fillet all around (see photo).

The servo hatches are fixed to the underside of the wing with 4 small sheet-metal screws provided. This kind of servo mounting allows changing of a servo within a few minutes, if needed, easily within the time between 2 flying rounds of a contest.

Now mount the standard phenolic C-ARF control horns in the same way you did for the elevators, again using a horn alignment template to ensure the holes for the quick-links in both horns are exactly perpendicular to the hinge axis, and identical on both wings. The quick-link hole in the horn should be 25mm from the bottom wing surface.

Finally, centre the servo arms using your R/C and make the linkages from the M3 threaded rods supplied, with 2 quicklinks and 2 x M3 locknuts for each stab. Don't forget to 'Loctite' the quick-link and lock-nut on one end of each linkage. Do NOT use ball-links if you use these C-ARF

## Finished in 4 hours

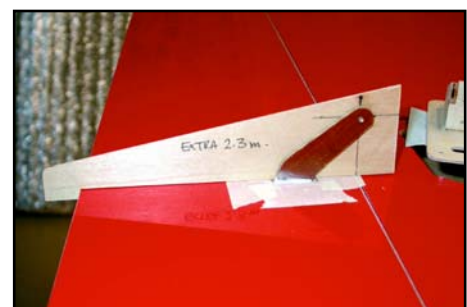
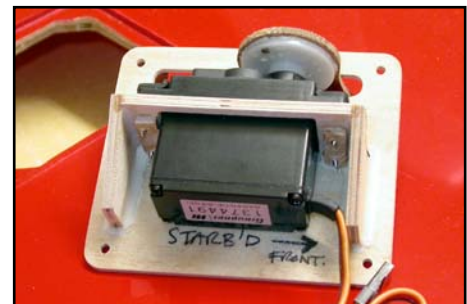
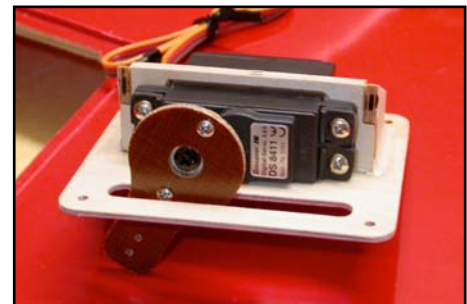

servo arms, because they will twist the servo arm and cause flutter. This is a solid experience and you should consider it a FACT.

**Servo choice:** One high quality servo (eg: Jr/Graupner 8411 or 8511) per aileron is quite sufficient for normal flying. However if you choose to fit 2 servos for each aileron, (using the extra position already moulded into the btm. surface of the wings) you will need to mill the slots for the horns in the ailerons. We have already installed hard balsa blocks inside to take these.

When making and fitting the horns for the outer servos remember that the distance from the hole in the horn for the quick-link must be exactly the same distance *from the hinge axis* (top of the wing) as the inner horns. Therefore, as the wing is tapered, the horns need to be a bit longer than the inner horns. Please make an alignment template to check that the distances from the *quick-link hole to the hinge axis* are exactly the same.

**Attention:** To prevent severe damage during any possible aileron flutter, we strongly recommend that you box the servo cutouts between the bottom and top wing surfaces with scrap 6mm balsa, at least at along both sides, to stiffen the bottom wing skin. (see photo on right)

*View of the C-ARF servo horns, shown fitted to standard 25mm Ø servo arms, and also a pair of the standard C-ARF phenolic control surface horns.*

*Note gluing surfaces properly roughed up with coarse sandpaper to ensure good glue bond.*



*The completed aileron linkage. Note locknuts used at both ends of linkage, and short pieces of tubing used on all quick-links to prevent them opening in flight.*

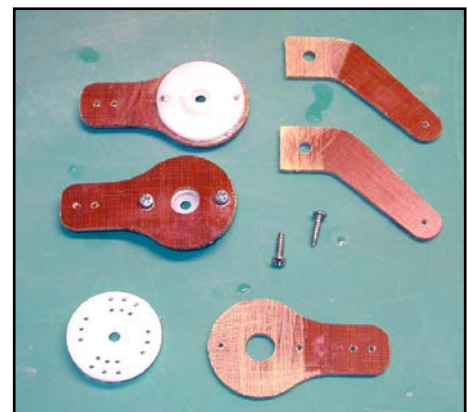

*This general view inside the front of the fuselage shows the rings, (made from scrap plywood) that provide the vertical face for the front wing retaining nuts, the main Landing Gear mounting bolts, and the small blocks glued onto the semi-circular cutout in the bulkhead for the spring that retains the mini-pipe muffler system.*



## Fuel Tank Base and Rudder Servo Plate

Finished in 2 hours

The rudder servo base plate and the fuel tank base are assembled from CNC milled balsa parts that have been laminated both sides with glasscloth, and vacuum-bagged, at the factory. This material gives exceptional strength with low weight and is more than adequate for this structure - so please don't modify it in any way.

The upper photo is the parts to assemble the rudder servo base, and the lower photo shows the an underside view of the completed fuel tank base. The 'H' shaped reinforcing part on the bottom of the fuel tank base is milled plywood.

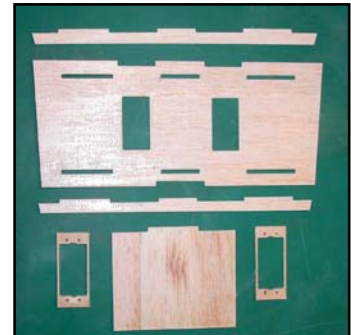

Sand all the mating surfaces to ensure a good glue joint, and glue together with thick CA or 30 minute epoxy, checking the fit in the model as you go. Don't forget to give all the bare edges of the milled balsa and plywood 1 thin coat of epoxy to fuel proof them before gluing in the model. Note that you must cut 2 small slots (6mm x 6mm) in the supports under the fuel tank base for the forward cable-ties that hold in the fuel fuel tank - it is difficult to do later!



The fuel tank base is big enough to hold a 960ml (Dubro #690) fuel tank, and you can adjust the balsa side cheeks as necessary if you fit a smaller tank. Once completed glue the whole assembly in place with 30 min. epoxy and milled fibre, and add 5 short pieces of 1" wide glass tape and epoxy to reinforce the joints to the fuselage sides and bottom (see photo). The semi-circular cut-outs on the bottom of the tank base should be glued on to the top of the main wing spar sleeve with epoxy and milled fibre.

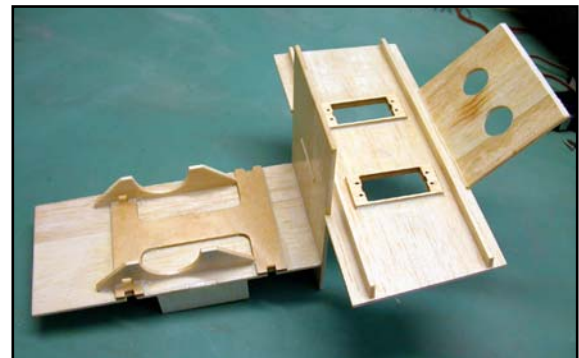

**Note:** Glue this assembly into the fuselage *after* you have completed the Landing Gear mounting and trial fitted your motor & muffler system. It makes construction much easier!

*This is a general view of the fuel tank base/rudder servo plate assembly glued in final position. Notice the 4 short lengths of glasstape and laminating epoxy to hold this structure securely. The 5th tape is on the bottom/front of the vertical plate between the rudder servo plate and tank base and cannot be seen here.*



## Engine Installation

**Finished in 4-5 hours**

It is easiest to do the motor and exhaust installation, or at least the trial fitting, before the fuel tank base and rudder servo plate are permanently installed. Here we show the installation of a Desert Aircraft DA-50 and PEFA ST-75 short mini-pipe, so all measurements shown are according to that set-up. Of course many other engines in the 50 - 75 cc range are suitable as well, and certainly the forthcoming DA-75, and Zenoah G62 will also be popular choices.

The moulded motor dome is already reinforced inside with plenty of carbonfibre tows and does not require any additional strengthening. There are 5 dimples moulded into the edges of it to show you where to drill the 5 x 4mm Ø holes for the M4 fixing bolts and 13mm Ø washers that hold it to the fuselage, which are screwed into 5 x M4 blind nuts that you must glue inside the firewall. We have already milled the holes for these blind nuts in the correct positions. When this is done remove the motordome and prepare for marking and drilling the 4 x 6.5mm Ø holes for fixing the motor stand-offs, in this case a DA-50. To do this accurately you will need a pair of compasses and a small 90° square (borrow them from a child's school bag if necessary!)

Use the moulding joint line across the centre of the motor dome as your main 'reference line'. First mark the exact centre of this line (approx. 70mm from the edge), and using a 90° square draw a vertical centreline intersecting this, exactly perpendicular to it. Mark off 53mm on this vertical line, and then offset to the right 28mm (using the 90° square), as shown in the photo here. This is the centre of the 1st mounting hole. Do *not* drill it 6.5 mm Ø yet!

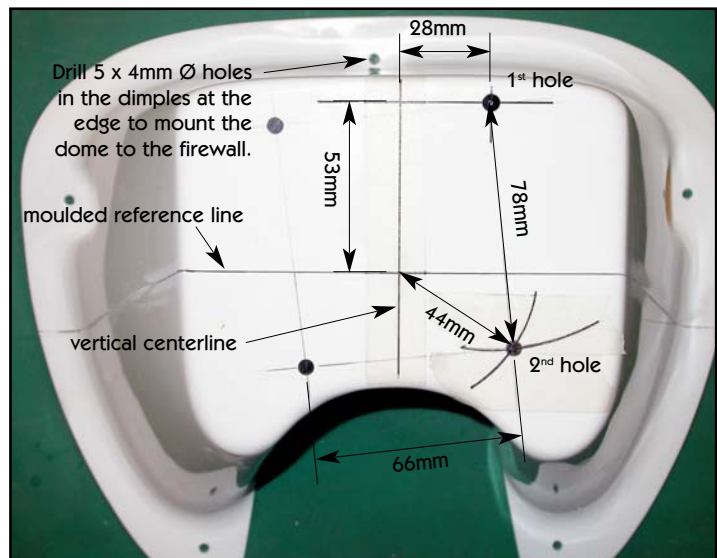

(above) Dimensions for mounting holes for DA-50 motor stand-offs.

Now, using the compasses, mark 2 arcs of 78mm from the centre of the 1st mounting hole, and 44mm from the intersection between the moulding reference line and the vertical centreline. Where these 2 arcs intersect is the centre of the 2nd hole. The centres of the mounting holes of the DA-50 are 78mm horizontally, and 66mm vertically. With the first 2 holes marked it is easy to mark the other 2 holes, using the 90° square and offsetting by 66mm from the 1st 2 holes. Before drilling these 4 holes double-check all dimensions by assembling the 4 stand-offs onto the motor and holding onto the motor dome. Drill the 4 holes 6.5mm Ø thru' the motor dome and mount the stand-offs with the M6 bolts and large Ø washers.

(below) Use a pair of compasses to mark the 78mm and 44mm arcs for positioning the 2nd hole.

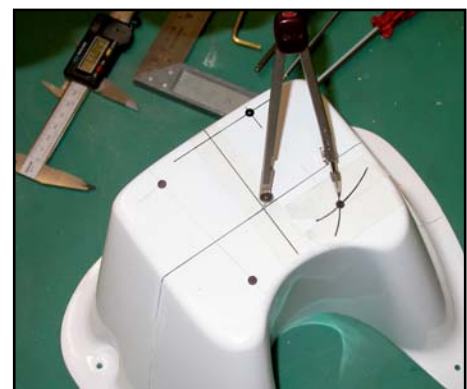

The stand-offs supplied with the DA-50 for this model need to be cut to approx. 77mm in length, to give spinner clearance to the front of the cowling, and the lengths adjusted by a very small amount to obtain the correct 2 - 3° sidethrust angle. No downthrust is required if using a 22 x 10 2-blade carbon propeller.

Adjustments to sidethrust before, and after, first flights can be made by adding large  $\varnothing$  washers between the back of the stand-offs and the face of the motor dome.

This motor position results in the DA-50 fitting completely inside the cowl, with only a very small cut-out needed for the top of the spark-plug cap.

In the future we hope to add the mounting hole dimensions for other popular motors to these instructions, or on the website.

**Standard Muffler:** If you are using a standard muffler just mount it onto the engine and check if you need to cut clearance holes in the bottom of the cowl for the exhaust outlets.

**Mini-Pipe:** An internal mini pipe installation is a little more complicated than the use of a standard muffler, but sometimes you don't have any choice, especially if you have noise problems at your club field. In Europe noise is always a problem, so Composite-ARF had to find a quiet and powerful solution, and we recommend the PEFA ST-75 short mini pipe. It comes with aluminium header and Teflon coupler, and it is designed especially for the DA-50 in this plane. This set-up gives the engine a nice throttle response and a perfect mid-range, and increases the top end power slightly.

The motor dome supplied is already moulded to take this mini-pipe and needs no modification, and the plywood bulkhead in front of the landing gear also has a semi-circular cutout prepared for this pipe. Mount the header and the pipe onto the motor according to the drawings supplied with the pipe. The front of the pipe is supported on the milled plywood bulkhead supplied in the kit (protected from the heat with a length of split silicone tubing), and this is screwed to the front of the firewall with 2 sheet metal screws. (see photo below/right)

Where the pipe passes through the bulkhead in front of the landing gear it must be properly supported on a flexible mount. The easiest way to do this is by using a narrow strip (approx. 6mm x 2mm thick) of stainless steel or brass (available from K&S metal centres in most good model shops), screwed down to 2 small wood blocks glued to the bulkhead. Form the correct shape in the strip by bending it around the pipe, and cover it with silicone tubing to protect it from rubbing on the pipe, which also prevents metal-to-metal contact which could affect your R/C system.

Hold the pipe down onto this support strap with a spring over the top, hooked over 2 short metal pins (3mm piano wire) that pass thru' the blocks on the sides of the bulkhead (see photo). It is easy to make a spring to suit. Just clamp a length of 0.8 or 1.0mm piano wire and an old screw-

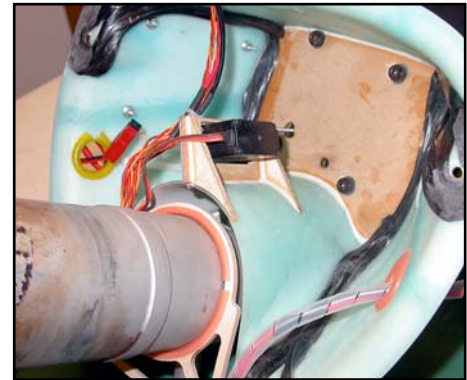

*2 views inside the back of the motor dome, showing the carbon tow strengthening, and the throttle servo mount from scrap 3mm plywood. Note the cutouts in the motordome for all cables are protected with split silicone tube (or rubber grommets).*

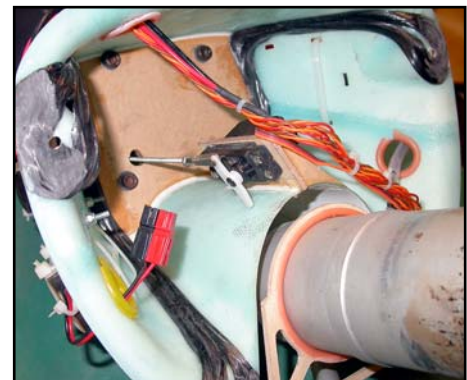

*Milled bulkhead around the front of the mini-pipe is also protected from heat with a split silicone tube, that is supplied in the kit.*



driver (about 4m Ø shaft) into a battery drill, and hold the wire in a glove while spinning it on slow speed. Bend 2 hooks in the ends to finish the job.

This simple mini-pipe retaining system has been proven for several years in our planes, and holds the pipe securely enough, while still being flexible enough to prevent it breaking under normal vibrations.

**Important Note:** If using a mini-pipe, C-ARF recommend that you protect the upper surface of the moulded carbon-fibre main landing gear legs by covering them with a thin sheet of 1mm plywood, attached with silicone adhesive. No other heat protection is necessary to the fuel tank base, or main spar sleeve when using the DA-50 and pipe.

Depending on your motor, you may need to make a simple plywood baffle plate inside the cowling to make sure that cooling air is directed around the engine cylinder head, instead of just going directly out of the opening in the bottom of the cowling. In any event, check that your motor is not overheating when you make the engine-running R/C range checks before flying.

Install the throttle servo in a convenient place inside the back of the motor dome, on a mount from scrap 3mm plywood, securely fixed to the moulded tunnel for the mini-pipe. Make up the linkage from the servo to the carburettor, and make a wire lever so that you can operate the 'Choke' for starting thru' the cut-out in the bottom of the cowling.

Drill holes in the motor dome as necessary for the fuel feed tube from the tank, and linkage to the throttle servo mounted inside the motor dome.

**Fuel proofing:** We highly recommend that you protect all the wood parts inside the front of the plane with one thin coat of 24 hr laminating epoxy, or similar, brushed on. Be careful not to add excess weight here - it only needs about 30 grams (1 oz) of epoxy to fuel proof the whole area inside the front of the plane.

**Note:** Please call your Composite-ARF Rep if you need any additional help with the motor and mini-pipe installation.

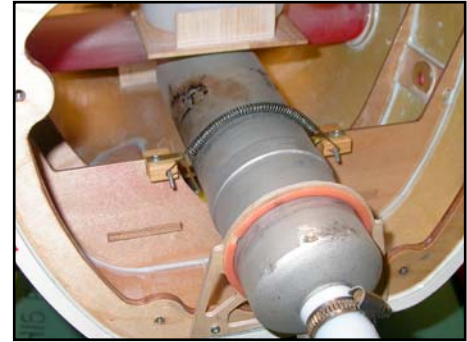

*(above) Mini-pipe mounted with the milled ply front bulkhead and a brass strap/spring at the back.*

*(below) Detail of the mounting strap, protected with a silicone tube, and the spring that goes over the pipe, hooked over 2 steel wires glued into the blocks.*

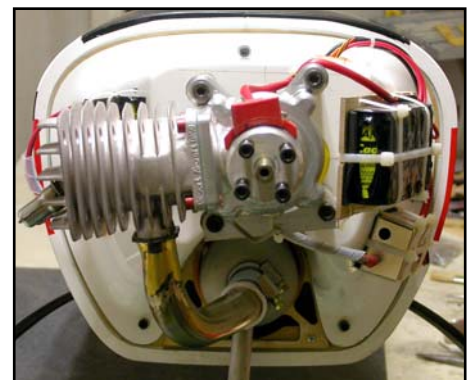

## R/C & Gear Installation

## Finished in 3 hours

The idea when designing this model was to keep the total \$\$\$ and time investment in the aircraft as low as possible for the owner, with a simple R/C installation, while still being more than sufficient for safe operation - and maintaining the proven pedigree of our contest-winning 2.6 and 3 metre Extra 330's.

It is not necessary to use dual receivers and a separate power-bus system, such as we recommend for the larger versions of the Extra 330, as most owners will only install 6 power servos for the main flight controls. Of course the choice of using a single, or dual, receiver NiCads and switches is up to you. At Composite-ARF we recommend either using a single 5-cell 2000 mAH pack for the Rx, or two 5-cell 1200 - 1400 mAH packs and dual switches if you prefer. A 4 cell 1200 - 1400 mAH nicad for motor ignition is fine. (Please double-check in the manual for your R/C system if the use of 5-cell Nicads is recommended, or not)

If you choose to use dual Receiver batteries then we highly recommend that you use properly designed, high quality, switches capable of carrying the current that 6 digital high power servos can draw during freestyle manoeuvres, such as the Power Switches and PowerBox crossover units that we supply. See website for details.

With the set-up described in this instruction manual, using a DA-50 motor with mini-pipe, and batteries and servos positioned as shown, you will not need any additional ballast in the nose to obtain the correct 'Centre of Gravity' for pattern flying.

Both the receiver NiCad(s) and the Nicad for motor ignition are fixed to the sidewalls of the motor dome, either side of the motor, and there is lots of space for this. We recommend using a 3mm thick plywood plate, bolted thru' the side of the motordome as a mount. Fit the batteries with a sheet of rubber behind them for vibration insulation, and fix securely with cable-ties as shown in the photos here, as the forces on these heavy items during high 'G' manoeuvres is extremely strong.

Please do make sure that you use good quality extension leads, of heavy gauge wire with gold-contact connectors, to all the servos. Certainly we recommend that all servo leads and extensions longer than about 30cms (12") are fitted with ceramic chokes (ferrite rings) to prevent RF noise, at the receiver end - normally within 100mm (4") of the receiver.

Make sure that all extension leads, servo

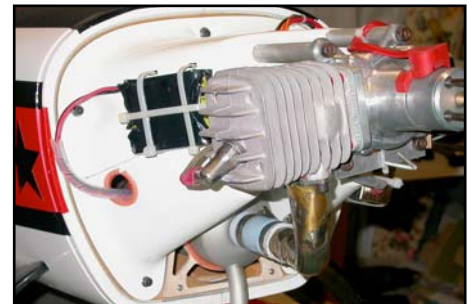

cables and tubes are fixed to the side of the fuselage and cannot come loose when subjected to high 'G' forces during flight.

It is up to you whether to use 'Y' leads to connect the rudder, elevator and aileron servos together - or use separate Rx channels for all the main functions if you have enough spare channels available.

We position the receiver on the angled plate behind the rudder servos, which keeps it (and the antenna) furthest away from the high-voltage ignition system. It sits on a thick foam anti-vibration pad, and is held in position with 2 rubber bands looped around the ends of a plywood stick glued under the holes in the balsa/composite plate (see photo in Rudder Servo Plate section, page 22). If you position the Rx as we have shown, then you can run the antenna wire along the bottom of the fuselage and then vertically through the top of the fuse behind the cockpit and back towards the vertical stab. Keep it as far as possible away from the extension cables for the elevator servos and the closed-loop rudder wires.

Composite-ARF advise you to keep all the cables between the motor ignition battery, ignition switch, and high voltage ignition unit as far away as possible from the R/C system.

Protect all cables from chafing where they pass thru' the holes in the motor dome with rubber grommets, or short lengths of split silicone tubing glued around the edges of the holes. Especially if you have installed the mini-pipe set-up, you also must make sure that no fuel tubing or wires can come into contact the hot pipes.

The fuel tank is held to the tank base with 3 large cable-ties as shown. If you choose to fit a smoke system and fit a smaller main fuel tank, you can fit the smoke tank alongside the fuel tank, but make sure you still have easy access to the plastic nuts that go on the front wing mounting dowels.

**Final check:**

Now check that you have fixed all components securely. Make sure that nothing can move. Keep in mind that all components inside the aircraft are loaded with the same G's as the wing and the wing spar during aerobatic manoeuvres. Check engine, cowling, wing and stab mount carefully again! Then you can go on set up all the linkages, control throws and R/C system as described below.

The assembly of the model should be completed in about 25 - 26 hours, excluding any painting or decals trim you want to add.

---

## Paint and Decals

The standard red/white 2.3m Extra 330L was designed for the customer to apply the final finishing and graphics of their choice, allowing you to apply your own scheme to make your own plane a bit 'individual' if you wish.

As an optional accessory available for this kit we have a 'Paint and Vinyl mask' set. This includes computer-cut self-adhesive Vinyl (black or blue) to allow you to create our 'House scheme' for this plane, as well as the 2-component red paint and the correct hardener.



This is the same paint that we use during manufacture of the models, and is extremely easy to spray, quick-drying, and fuelproof. You can use almost any thinner/reducer, but a standard 2-component fast type works best. Thin about 20 - 25% by volume, and make sure you spray in a warm place, at least 17° Celsius, to ensure quick-drying with minimal chance of dust particles sticking to the wet surface, and the highest gloss. Additionally this paint polishes up very well after 24 hours curing. The ratio of paint to hardener is 4:1 by volume, but it is not at all critical.

The colour scheme is quite simple to do, but shows up very well in the air, and can be enhanced with additional trim lines from vinyl as you wish. Actually you could easily do the 'house scheme' on almost the whole plane with vinyl if you prefer, substituting red vinyl (or any other colour) for the red paint - except for the cowling which has a compound curvature and therefore it is very difficult to do wide strips with self-adhesive trim. Of course you could paint just the cowling, which is a small area and could even be done with aerosols of matching colour.

The 3 drawings here give the dimensions and positions of the red stripes, and you will find the vinyl cut to suit this scheme, including 3 different sizes of stars. The largest are for the wing, the medium ones for the front of the fuselage, and the smallest for the stabilisers.

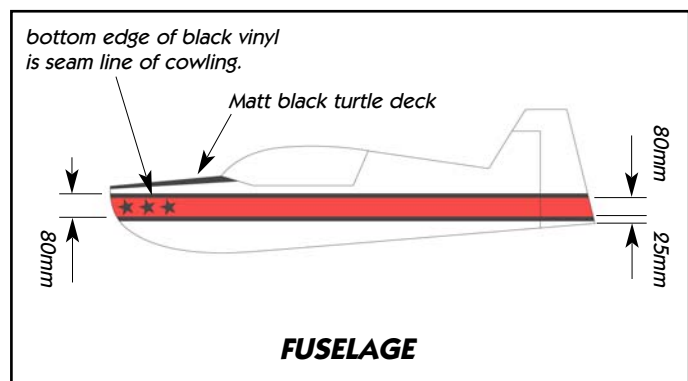
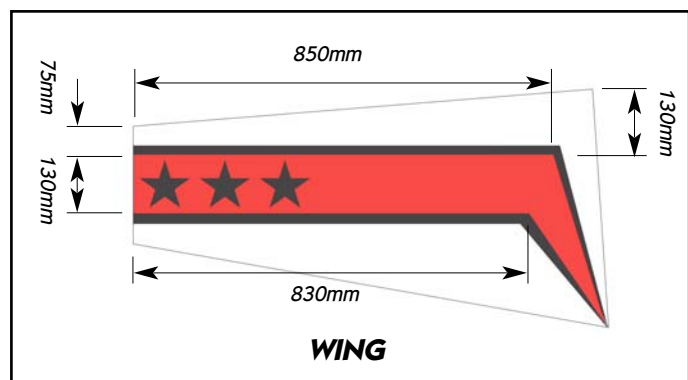

Of course it is not our aim, or even possible, to teach you how to spray in this instruction manual, but to give you a few hints and tips.

The masking in preparation for painting is much more time-consuming than the spraying itself, especially with many long straight lines which are quite tricky to get exactly right. Once you have marked the positions of the red stripe at both ends of the fuselage, you can tape a piece of string against it at one end, pull it tight

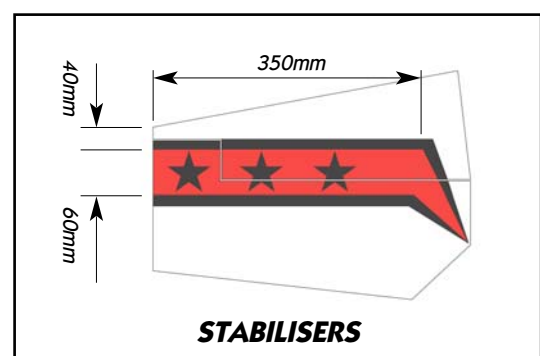

and make pencil marks every few inches to guide you as you are applying the masking tape. The pencil comes off with cleaning alcohol.

For straight lines we can recommend the 3M Finesline (blue) type in 10 or 15mm width, and for curves the green type in 6mm is excellent and can be pulled around surprisingly a tight radius without kinking. If you run the back of a fingernail down the edges of the tape after it is applied you will never get any paint bleeding under this tape. Once the exact lines are masked off cover the rest of the plane with 2 or 3 layers of paper, using glossy magazines so that the paint does not bleed through it, using paper masking tape to stick it in place firmly.

You absolutely do *not* need to apply any primer before painting, and would only add unnecessary weight, but you must very gently scuff all areas to give a good key to the paint. The best way to do this is with a piece of 3M 'Scotchbrite', and the green type is the perfect grade for this. If this is not available you can use 100 grit wet-and-dry paper. Before spraying, wipe the area for over with clean paper towels and alcohol (or thinner/reducer) and let it dry completely. Finally a quick wipe with a 'tack-rag' will remove any stray hairs or fluff.



Spray a very light mist coat first, to seal the edges of the masking tape, wait a couple of minutes for it to flash off (almost touch dry), and then 1 or 2 flow coats until the colour matches the red on the underside of the plane. Make sure that the red on all parts has the same depth of colour, and that you don't build up too much thickness at the edges, against the masking tape.

When the paint is dry you can apply the vinyl, following the edges of the paint to make sure it is straight. Be careful not to wear any woolly or fluffy clothes when doing this - as even the smallest particle under the vinyl looks like a mountain! Air bubbles are also something to beware of.

The matt black anti-glare panel in front of the cockpit can be sprayed with an aerosol of polyurethane (1 component) flat black, and this is also fuel-proof against petrol/gasoline.

If you wish to tint, or paint solid colour, inside your canopy we recommend that you use one of the small aerosols of polycarbonate paint normally sold for painting the inside of clear plastic R/C car bodies. Make sure that the surface is completely clean and free of all particles first, wipe it with denaturised alcohol or similar to remove any greasy finger marks, and paint with many, many very light mist coats to get even coverage. The 'Lexanit', and Tamiya brands work well, and are available in a wide variety of colours.

Of course we at Composite-ARF would be very happy to see some photos of your finished Extra 330L, and you can email them to us at: [feedback@composite-arf.com](mailto:feedback@composite-arf.com).

## Setting Up Your Aircraft

### CG:

Set the Centre of Gravity to 100 - 105mm behind the leading edge at the wing tip for the 1st flights. Hold it with a helper at both wing tips in this position and make sure the plane balances horizontally. This is the 'pattern' CG position.

After you are confident with the plane, you can move it backwards to 110mm, or even 115mm, from the leading edge at the wingtip, but this is definitely a '3D/Freestyle' CG setting and should not be used for the first flights. With this rearward CG you will need to use the high rate control throws shown below.

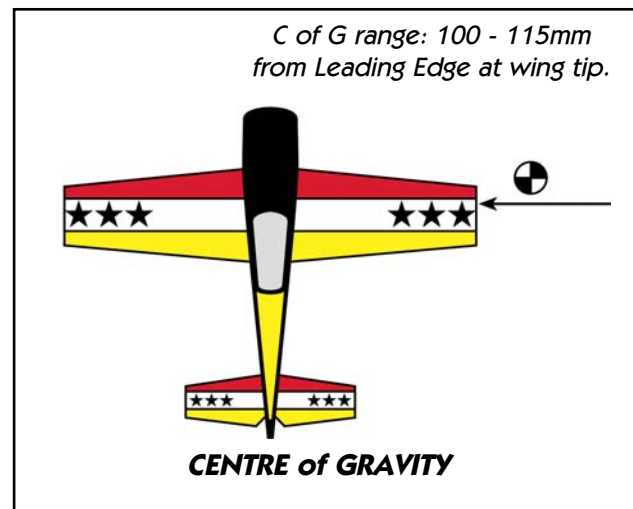

Don't forget to balance the plane laterally as well.

### Engine Thrustline:

Already given in the instructions before, down thrust is 0 degrees and right thrust is 2-3 degrees, depending on the prop used. We recommend a 22 x10 Carbon prop for any 50 - 60cc engine. It is a very quiet and powerful solution. They are normally CNC-designed, so the prop is balanced perfectly statically, dynamically and aerodynamically, which keeps the vibration down to a minimum.

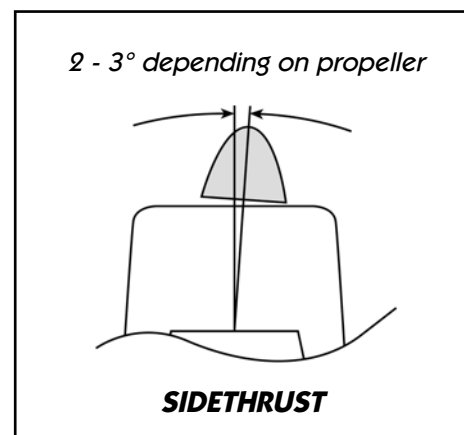

### Control Throws:

All measurements are made at the root/trailing edge position.

### Elevator

All controls should be set with a dual rate switch. On high rate the elevator should really be at maximum, up to 50 degrees both sides (approx. 75mm), but in this case with 50% exponential. Low rate should be no more than 35mm (1 1/4") both sides. This is the perfect throw for nice and crisp snaps. If you like you can add about 20% exponential to the low rate setting as well.

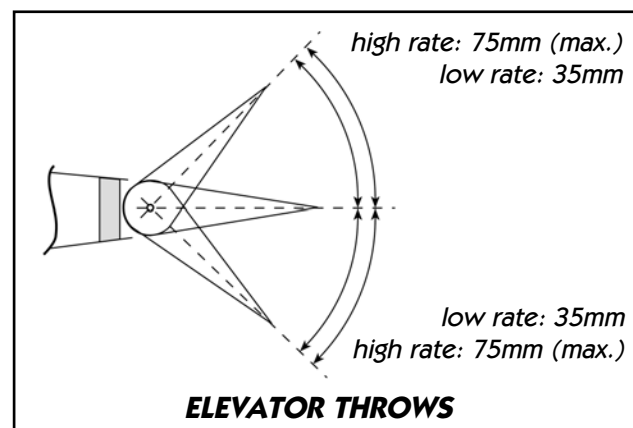

**Rudder**

Set the high rate to maximum throw (about 150mm) both sides, and at low rate reduced to about 100mm. The Extra needs quite a lot of rudder for nice stall turns, so you should at least add 25% exponential for smooth tracking corrections. At the same time you should remember that the Extra rudder is VERY sensitive, and the plane starts shaking at high speed if the rudder linkage is not really rock solid. So check your linkages and closed-loop cables again and make sure that there is NO slop at all ! On the other hand these characteristics are also the reason for best rudder sensitivity at the slowest 3D-speeds.

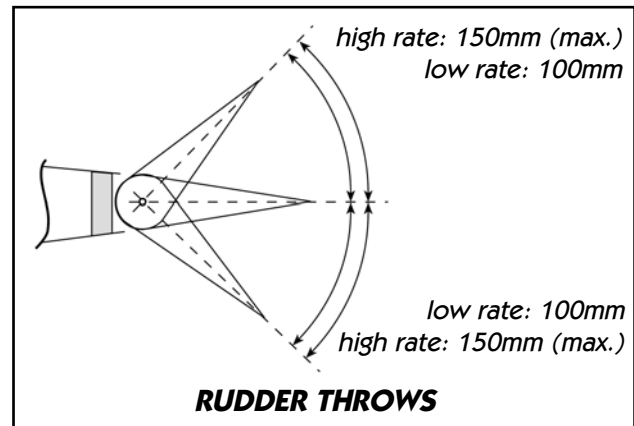

**Ailerons**

Aileron throw for high rate is 50mm (measured at root) both up and down. Use at least 30% exponential at high rate. For low rate you should decrease the throw to the TOP to 30mm, to the BOTTOM to 35mm. Yes, you're right - this is a *reversed* differential due to the hinge line being in the top skin instead of on the centre line. You will have to finalise this differential figure during flight, as mentioned earlier in this instruction book.

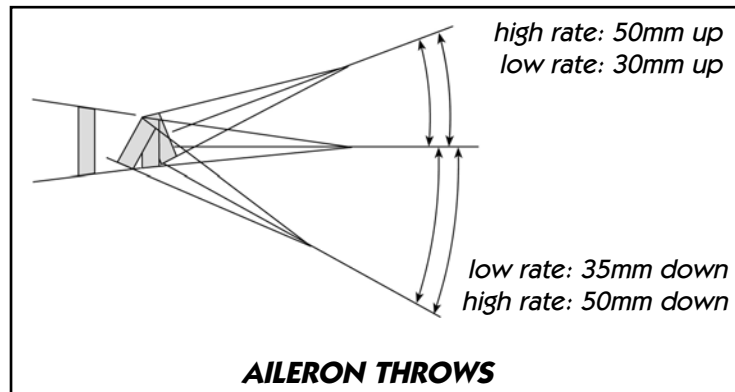

At high rate, for 3D manoeuvres, this doesn't effect the rolling too much, so you can maximize the throws to whatever is mechanically possible, even more up than down if you wish. You may need to lengthen the slots in the servo hatches by 2mm or so at the front to obtain these high rate throws.

**In General**

Your Extra has very large control surfaces. This makes it very sensitive and reactive. It is always possible that these huge control surfaces can flutter at high speeds if the assembly, servo installation and linkages are not made perfectly. The design is so strong that even a flutter will not damage the structure of the plane. But if a servo gear strips, the flutter will not stop until the plane slows down (or hits the ground...).

So please do yourself a favour, and make sure that you only use the best servos available, and take the utmost care making your linkages. Check every linkage for slop, and rather reduce the maximum throw than risking a high speed flutter due to sloppy servo gear or linkages. To prevent this for sure, we recommend reduced control travels (reduced by using short servo arms, not by using electronic settings). Using 2 servos per control surface as described in this manual will never overload or damage high quality servos, even if the maximum travel of each servo is slightly off. The aileron control surfaces have enough torsion flexibility so that damage to the servos should not occur.

The Composite-ARF TOC 3-Metre Version of the Extra 330S is known for very good and crisp 'snapping'. We think that the 2.6m version snaps even better, and the 2.3m version is just as good. It's like an explosion ... and it still stops immediately that the sticks are released. Be aware of this fact when you try it for the first time.

The trick for nice crisp 'snaps' is to stall the plane with a quick hit of 'up' elevator, and then release the elevator to zero, while you give full rudder and aileron together. But of course, you know this needs some practice to make it perfect every time !

Perfect knife edge tracking is achieved by mixing in slight up elevator and opposite aileron to the rudder movement. From our experience as little as 5 - 7% 'up' elevator and 1 or 2% of opposite aileron are needed.

Now your Extra seems to be ready for the first flight. Always keep in mind, that you have a rock solid, but still sensitive, contest tool in front of you, which, if used as it is designed will give you many hours of pleasant flights. The performance of this aircraft is unlimited, and if maintained regularly and carefully, you will enjoy it's performance for many, many hours. With this aircraft you have the potential to move up to the unlimited "cracks", it's up to you now! You can't blame it on the aircraft anymore....

*Have Fun!*

**Notes:**

We hope that you enjoyed building your Extra 330L. This manual is the beginning of our attempt of a new standard of Composite-ARF instructions, and we would like to complete all our products with this style of manual in the future. Please let us know whether you like this all new instruction manual, and if you have any ideas to improve it.

Also let us know, if you think that any hardware is missing or inadequate. We tried to make this airplane as complete as possible. With good feedback from customers you will help us to continue making good things even better. We appreciate your comments very much.

Email: [feedback@composite-arf.com](mailto:feedback@composite-arf.com)

*Thank you!*

**Your Composite-ARF Team**



## Appendix:

### Extra 330L, 2.3m Kit Stückliste / Packing List

Art.-Nr.	Anzahl Beschreibung Deutsch	Description English
1	Rumpf	Fuselage
1	Fläche rechts	Right wing
1	Fläche links	Left wing
1	Höhenleitwerk rechts	Right stab
1	Höhenleitwerk links	Left stab
1	Höhenruder rechts	Right elevator
1	Höhenruder links	Left elevator
1	Seitenruder	Rudder
1	Motorhaube	Cowling
1	Kabinenhaubenrahmen	Canopy frame
1	Radverkleidung rechts	Right wheel pant
1	Radverkleidung links	Left wheel pant
1	Fahrwerksbein rechts	Right landing gear, carbon
1	Fahrwerksbein links	Left landing gear, carbon
1	Kleinteilebeutel mit gefrästen Zubehörteilen	Small parts bag "milled parts"
1	Leitwerkssteckungsrohr 20x300mm	Stab tube 20 x 300 mm
1	klare Kabinenhaube	Clear canopy
3	Stahl-Pin 2mm x 600 mm	Steel pin 2 mm x 600 mm
1	Kleinteilebeutel	Hardware bag
1	Bauanleitung Englisch	Instruction book English

### Kleinteilebeutel / Hardware bag:

Art.-Nr.	Anzahl Beschreibung Deutsch	Description English
2	Radschrauben M 6 x 55mm	Screws for axles, M6 x 55mm
2	Stopmuttern M 6	Lock nuts M6
2	Muttern M 6	Nuts M6
4	Unterlegscheiben M 6,4	Washers 6.4 mm
4	Stellringe 6 mm	Wheel collars 6 mm
2	Blehschrauben 3,5 x 16 mm	Sheet metal screws 3.5 x 16 mm
4	Inbusschrauben M 6 x 20	Allen screws M6 x 20 mm
9	Inbusschrauben M 3 x 16 mm	Allen screws M3 x 16 mm
9	Inbusschrauben M 3 x 12 mm	Allen screws M3 x 12 mm
13	Einschlagmuttern M 3	Blind nuts M3
6	Gewindestäbe M3 x 45 mm	All thread M3 x 45 mm
2	Gewindestäbe M3 x 60 mm	All thread M3 x 60 mm
1	Packung 0.8 mm Stahl-Litze	Pack steel cable 0.8 mm dia.
2	Schraub-Ösen M3	2 thread ends for steel cable 0.8
4	Quetschhülsen Messing, id 2mm	Crimp tubes, 2 mm inside dia.
4	Kugelköpfe M3	Ball links M3
4	Stopmuttern M3	Lock nuts M3
14	Muttern M3	M3 nuts
14	Gabelköpfe M3	Spring steel clevises M3

**Frästeile-Beutel / Milled Parts:**

<b>Art.-Nr.</b>	<b>Anzahl Beschreibung Deutsch</b>	<b>Description English</b>
1	Fräsplatte Sperrholz 3mm, Kleinteile	Milled plywood, 3mm, small parts
1	Fräsplatte Novotex 2mm, Servo/Ruderarme	Milled phenolic 2mm, control/servo horns
1	Fräsplatte Sperrholz 3mm, Kleinteile	Milled plywood, 3mm, small parts
4	Servoaufnahmen Querruder	Servo mounts ailerons
2	Farbige Servodeckel	Coloured servo hatches

**Lieferbares Zubehör / Available Accessories:**

<b>Art.-Nr.</b>	<b>Anzahl Beschreibung Deutsch</b>	<b>Description English</b>
-	'Paint and Vinyl Mask' set	'Paint and Vinyl Mask' set
-	Spornfahrwerk mit Rad 50 mm	Tail gear setup with 50mm Ø wheel
-	Desert Aircraft DA-50 motor	Desert Aircraft DA-50 motor
-	PowerSwitch 20A (for dual NiCads)	PowerSwitch 20A (for dual NiCads)
-	PowerBox 40 (Dual Nicad crossover unit)	PowerBox 40 (Dual Nicad crossover unit)